



**FUNG YUAN** Sincere / Innovation / Profession  
Responsibility / Enthusiasm

# 全自動雙面套袋 封口包裝機

# FAL-6020-2



包裝範例 Samples

Automatic Two-Side Sealing Machine ( Sleeve Wrapper )



鋒源機械有限公司  
FUNG YUAN MACHINERY CO., LTD.



Sincere / Innovation / Profession  
Responsibility / Enthusiasm

# 全自動雙面套袋 封口包裝機

# FAL-6020-2

Automatic Two-Side Sealing Machine ( Sleeve Wrapper)

## FAL-6020-2 全自動雙面套袋封口包裝機 Automatic Two - Side Sealing Machine ( Sleeve Wrapper)

### 特點:

- 包裝材料：PE、PVC、OPP均可使用。
- 適用產品：禮盒、食品罐頭、特產品、藥材、印刷、書籍、日用品、電器製品、玩具、五金工具、運動器材、木業製品、地磚類.....等。

### Features :

- Packing materials : PE、PVC & OPP.
- Usage : Gift boxes, foods can, special products, medicines, printing articles, books, daily necessities, electric appliances, toys, metallic tools, sporting goods, wooden wares, & tiles, etc.

### FAL-6020-2 規格表 / FAL-6020-2 SPECIFICATION :

| 規格 SPECIFICATION                      |                         | 機型 MODEL | FAL-6020-2            | FAL-9040-2            |
|---------------------------------------|-------------------------|----------|-----------------------|-----------------------|
| 包裝尺寸(公厘)<br>Packing Size(mm)          | 最長 X 最短 Max. L x Min. L |          | 400 x 200             | 700 x 200             |
|                                       | 最寬 X 最窄 Max. W x Min. W |          | 350 x 60              | 550 x 60              |
|                                       | 最高 X 最低 Max. H x Min. H |          | 180 x 50              | 380 x 50              |
| 包裝量(次/分) Packing Capacity (time/min.) |                         |          | 5-15                  | 5-15                  |
| 電源 Power                              |                         |          | 220V x 0.6KW          | 220V x 0.8KW          |
| 空氣壓力 Air Pressure                     |                         |          | 5kg / cm <sup>2</sup> | 5kg / cm <sup>2</sup> |
| 機械尺寸(長x寬x高) Machine dimension (LxWxH) |                         |          | 1450 x 1880 x 1615    | 1740 x 2180 x 1825    |
| 重量 Weight                             |                         |          | 300kgs                | 400kgs                |

## FM 系列 FM SERIES / PE 收縮機 PE SHRINK TUNNEL

### 特點:

- 不傷品質、節省電力、增加利潤。
- 熱縮爐特殊導風板、熱風出力平均，熱輻射均勻，輸送以滾筒帶動經久耐用，速度快慢可調節。

### Features :

- To assure the quality without being damaged, to save electricity and to increase profits.
- Heat oven for contracting will send out even heat radiation. Delivery is done by roller with durability. And the speed is controlled and driven by DC motor.

### FM 系列規格表 / FM SERIES SPECIFICATION :

| 機型 Model   | 規格 Size | 包裝尺寸 Packing Size (WxH) mm | 包裝能力 (公尺/分) Packing Ability (Meter/Min) | 電源 Power    | 耗電量 Power Consumption | 內爐尺寸 (長x寬x高) Inner Tunnel L x W x H (mm) | 機械尺寸 (長x寬x高) Tunnel Overall L x W x H (mm) |
|------------|---------|----------------------------|---|-------------|-----------------------|--|--|
| FM - 4525  |         | 300 x 220                  | 1-10M                                   | 220V / 380V | 9 KW                  | 900x450x250                              | 1500x650x1470                              |
| FM - 6040L |         | 450 x 320                  | 1-10M                                   | 220V / 380V | 15~19.5 KW            | 1200x600x400                             | 1800x800x1620                              |
| FM - 7540L |         | 600 x 320                  | 1-10M                                   | 220V / 380V | 15~19.5 KW            | 1200x750x400                             | 1800x950x1620                              |
| FM - 9040L |         | 700 x 320                  | 1-10M                                   | 220V / 380V | 19.5~24 KW            | 1200x900x400                             | 1800x1100x1620                             |

### 全自動雙面套袋封口包裝流程 Packing Flow

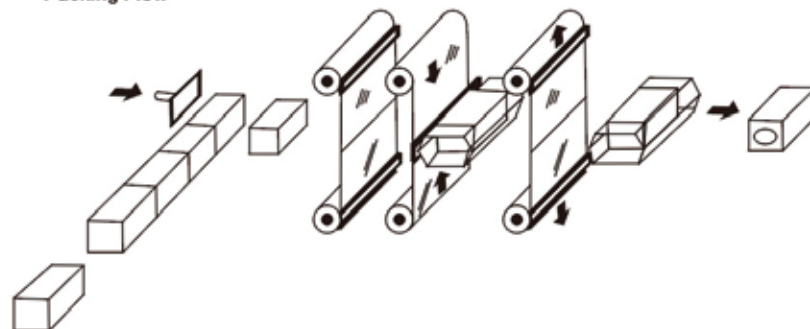

### 包裝方式圖例 Example of collective packaging

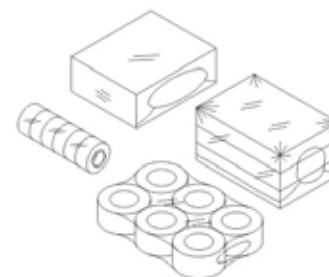

### 機械尺寸圖 M / C Dim. Illustration

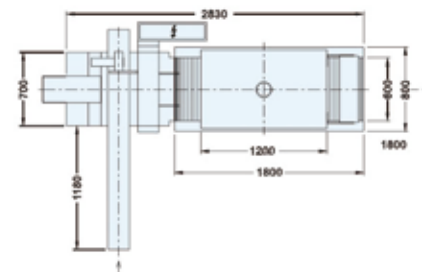

## 鋒源機械有限公司 FUNG YUAN MACHINERY CO., LTD.

公司：台中市豐原區圓環北路二段321號  
工廠：台中市豐原區東北街187號

Office : No.321, Sec.2, Yuan Hwan North Rd., Feng Yuan Dist.,  
420 Taichung City, Taiwan

Factory : No.187, Tung Pei St., Feng Yuan Dist., Taichung, Taiwan

TEL : 886-4-25232986, 25227318, 25253217-8 FAX : 886-4-25276828

Http : //www.fungyuan.com E-mail : fungyuan@ms25.hinet.net